

ACP 
AUSSIE CONCRETE PRODUCTS
Ph: 3245 1220 **CONCRETE SLEEPER RETAINING WALLS**
* NO TERMITES * NO CHEMICALS * NO PAINTING * NO MORTAR * NO WOOD ROT * FIRE PROOF



INSTALLATION GUIDE FOR CONCRETE SLEEPER RETAINING WALL



STEP 1: BASE PREPRATION

Clear and level your site where you plan to build the retaining wall. Please ensure you leave 200mm behind the retaining wall area for backfill.

STEP 2: ALIGNMENT & HEIGHT

Place a star piquet at the ends of the proposed wall. Drive the star piquet in, with a lean back, of 40mm in each 1m high.

Attach 3 string lines at each end of the wall, 1 for the height of the posts and two for the back face of the posts.

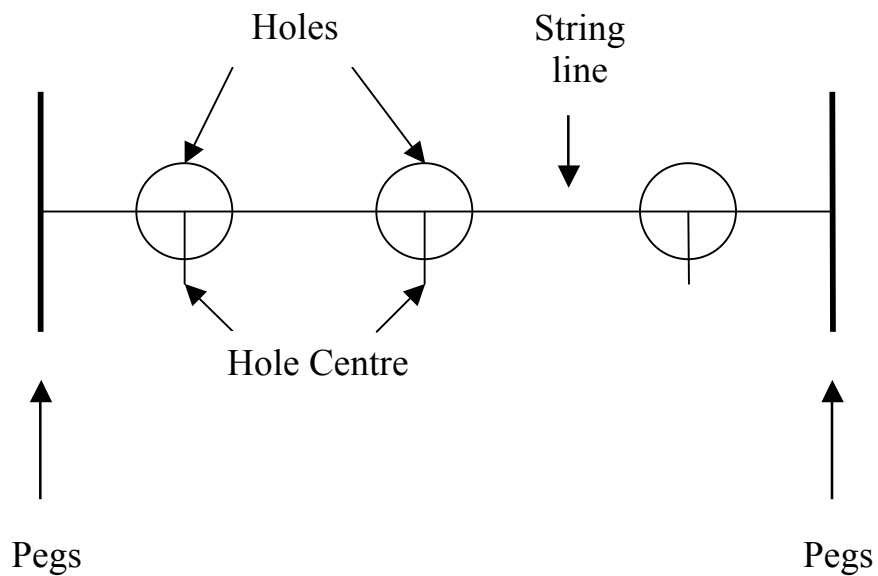

STEP 3: POST HOLES

Starting from one end of the wall, mark a cross on the ground at 1.530mm intervals - this will vary on the length of sleeper used.

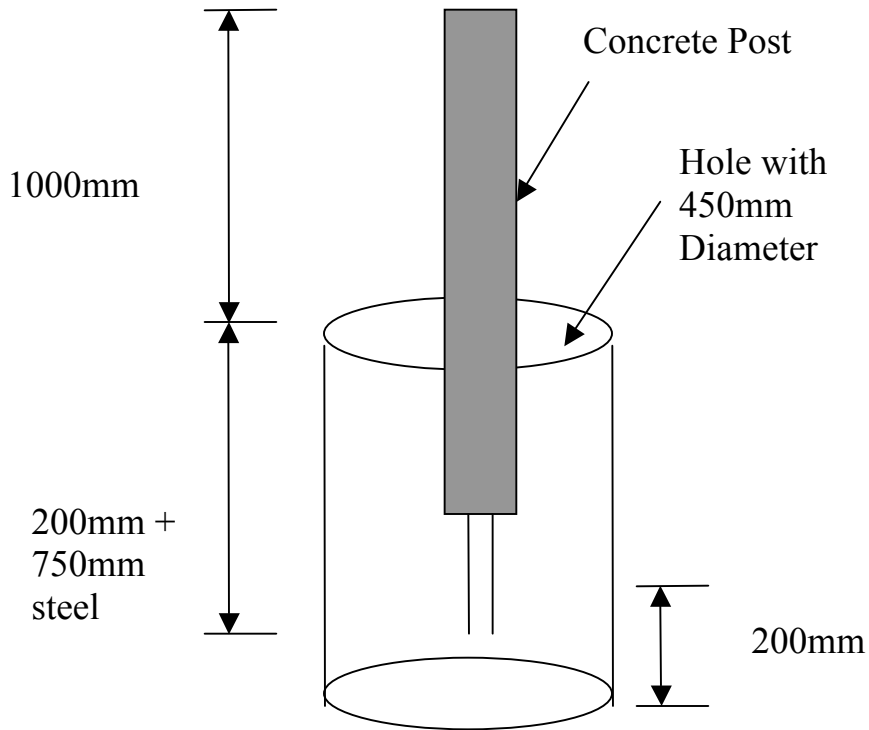

STEP 4: AUGER HOLES

Auger holes as per engineer specifications –

	RETAINING WALL WITH OPEN FENCING ONLY WITHIN 1M OF TOP OF WALL (I.E. NO WIND LOADS)		RETAINING WALL WITH UP TO 1.0M HIGH FENCE ON TOP OF WALL (N2 WIND RATING)	
WALL HEIGHT	POST SPACING	FOOTING DEPTH	POST SPACING	FOOTING DEPTH
1000	2000	1200	2000	1400
1200	2000	1400	2000	1600
1400	1500	1600	1500	1800
1600	1500	1800	1500	2000
1800	1500	2000	1200	2200
2000	1500	2200	1200	2400
2200	1200	2400	1200	2800
2400	1200	2600	1200	3000
2600	1200	2800	1200	3200
2800	1200	3000	1200	3600
3000	1200	3200	1200	3800

STEP 5: POST LEANBACK

For all walls 1m or higher they must have a minimum of 35mm in every 1m high, lean back. Any wall over 1m high must be certified by a registered Engineer.

Council approval is also necessary.

STEP 6: SLEEPER ALIGNMENT

Depending on how high a wall you are putting up, turn each post over so as the face is downwards and measure from the top of post down and draw a line across the back of the post with a thick marker. Measure from the finished end not the cut end:

- Two High 400mm
- Three High 600mm
- Four High 800mm
- Five High 1000mm.

This will give you the line of the bottom sleeper when posts are upright.

STEP 7: POURING CONCRETE

Pour concrete into holes, one at a time. Make the concrete stiff. If using ready-mix concrete, order 20/20, 60 slump. Refer to guide for the amount of concrete required for each hole.

STEP 8: SETTING POSTS

Starting from one end, start setting posts in. Try to concentrate on one post at a time. Lowering the posts, so the back is just off the stringlines, and the top height is just under the top stringline. Using a spirit level ensure that the posts are perpendicular (plumb), on the sides. Continue checking distance between posts, once happy with one post move on to the next.

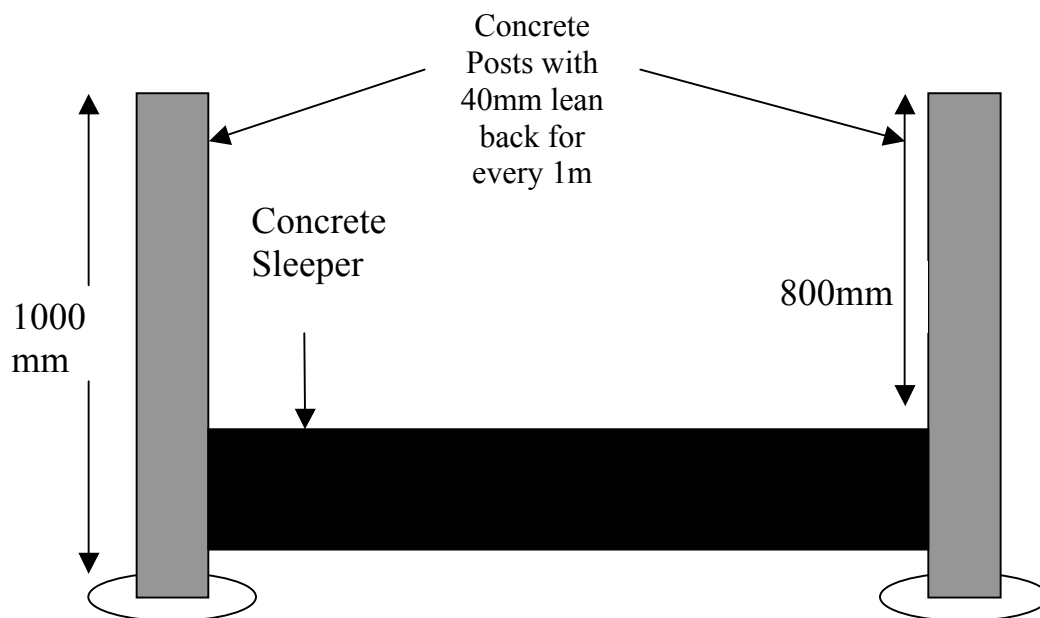

STEP 9: CONCRETE PAD

Once you are happy and all posts are at the height required are in a straight line, and perpendicular (plumb), go along and level a pad of concrete behind each post up to the mark on the back of each post . This will create a ledge for your first sleeper to sit on and keep everything level.

STEP 10: BUILDING THE WALL UP

Do not place sleepers behind posts for at least three days. Allow for concrete to cure. Place the agpipe at the base, ensuring, the water can escape at the end. Backfill with gravel, to 200mm from the top. A soil plug is then placed in, to fill the wall to the top.

STEP 11: BACKFILLING

Ensure when backfilling do not push dirt from behind into the back of the wall with any machinery. Always place dirt/fill from the top, when using a Bobcat/Dingo, or if you prefer, by hand.

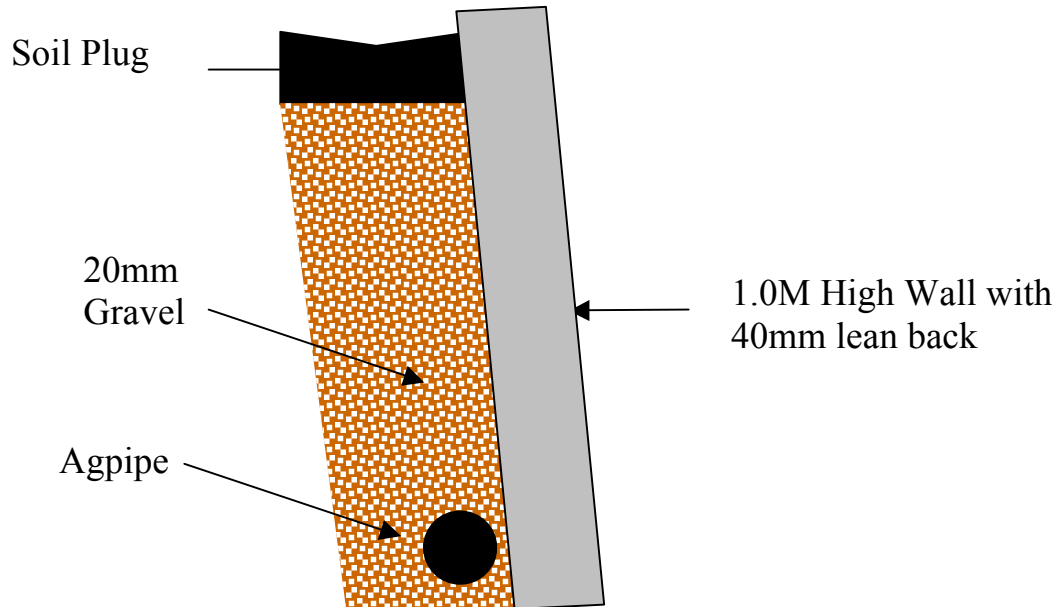

STEP 12: ENJOY!

Once backfilled and landscaped sit back and enjoy an Aussie Concrete Products retaining wall that will never have to be replaced.

- **PLEASE NOTE** – Any walls over 1.0m high must be referred to an engineer and be council approved.